



Bill White
Pasquale Catalano
Michal Holenia
Pasi Laakso

IBM System z Qualified WDM: Cisco ONS 15454 MSTP Release 9.2

This IBM® Redpaper™ is one in a series that describes System z® qualified optical Wavelength Division Multiplexing (WDM) vendor products for GDPS® solutions with Server Time Protocol (STP). The products that we describe in this series are also the IBM-supported solutions for non-GDPS applications. Non-GDPS applications include the protocols that are needed for cross-site connectivity of a multisite Parallel Sysplex® or one of the remote copy technologies that we describe in this paper. GDPS qualification testing is carried out at the IBM Vendor Solutions Connectivity (VSC) Lab in Poughkeepsie, New York (NY), United States of America (USA).

IBM and Cisco Systems Inc. successfully completed qualification testing of the Cisco ONS 15454 MSTP platform. In this Redpaper publication, we describe the applicable environments, protocols, and topologies that are qualified and supported by System z for connecting to the Cisco ONS 15454 MSTP platform hardware and software at release level 9.2.

For current information about qualified WDM vendor products, registered users can visit the Library at the Resource Link™ web site:

<https://www.ibm.com/servers/resourceLink/lib03020.nsf/pages/systemzQualifiedWdmProductsForGdpsSolutions?OpenDocument&pathID=>

IBM Redbooks® publications for System z qualified WDM vendor products can be found at:

<http://www.redbooks.ibm.com/cgi-bin/searchsite.cgi?query=qualified+AND+wdm&SearchOrder=1&SearchFuzzy=>

System z GDPS qualification overview

GDPS is an enterprise-wide continuous availability (CA) and disaster recovery (DR) automation solution that can manage recovery from planned and unplanned outages across distributed servers and System z servers. GDPS can be configured in either a single site or in a multisite configuration. It is designed to manage remote copy configuration between storage subsystems, automate Parallel Sysplex operational tasks, and to perform failure recovery from a single point of control, which improves application availability. Historically, this solution was known as a Geographically Dispersed Parallel Sysplex™. Today, GDPS continues to be applied as a general term for a suite of business continuity solutions, which includes those that do not require a dispersed or multisite sysplex environment.

GDPS supports the following forms of remote copy in multisite solutions:

- ▶ IBM System Storage® Metro Mirror, a synchronous form of remote copy previously referred to as Peer-to-Peer Remote Copy (PPRC)
- ▶ IBM System Storage Global Mirror, an asynchronous form of remote copy for System z and distributed systems
- ▶ IBM System Storage z/OS® Global Mirror, an asynchronous form of remote copy for System z, previously referred to as Extended Remote Copy (XRC)

Depending on the form of remote copy that is implemented, the GDPS solution is referred to as:

- ▶ GDPS/Metro Mirror
- ▶ GDPS/Global Mirror
- ▶ GDPS/z/OS Global Mirror

GDPS also offers two solutions that combine the technologies of Metro Mirror with either Global Mirror or z/OS Global Mirror. This combination allows customers to meet requirements for continuous availability with zero data loss locally within metropolitan distances for most failures, along with providing a disaster recovery solution in the case of a region-wide disaster.

The solutions are:

- ▶ GDPS Metro/Global Mirror (GDPS/MGM), a cascading data replication solution for both System z and distributed systems data
- ▶ GDPS Metro/z/OS Global Mirror (GDPS/MzGM), a multitarget data replication solution for System z data

The GDPS solution is also independent of disk vendor, if the vendor meets the specific levels of Metro Mirror, Global Mirror, and z/OS Global Mirror architectures.

For more information about GDPS, visit the GDPS web site:

<http://www.ibm.com/systems/z/advantages/gdps/index.html>

IBM only supports WDM products that are qualified by System z for use in GDPS solutions. To obtain this qualification, WDM vendors obtain licensed IBM patents, intellectual property, and know-how that are related to the GDPS architecture, which gives vendors access to the proprietary IBM protocols and applications that are used in a GDPS environment, including Sysplex Timer®, InterSystem Channel (ISC), Server Time Protocol (STP), Metro Mirror, Global Mirror, and z/OS Global Mirror.

Licensing of IBM patents also provides the WDM vendor with technical information pertaining to future IBM releases. Qualified vendors typically license this information for an extended

period, which allows them to subscribe to the latest GDPS architecture changes and to be among the first to market with offerings that support these features.

Licensing status: We recommend that you check with your WDM vendor for current licensing status.

In addition, IBM tested and qualified these vendor products with the same test environment and procedures that were used to test the protocols that provide the required connectivity of a GDPS configuration. This testing includes functionality, recovery, and in some cases performance measurements. Having access to these test facilities allows IBM to configure a fully functional sysplex and to simulate failure and recovery actions that cannot be tested as part of a working customer environment.

IBM has the facilities to test and qualify these products with both current and previous generation equipment within the IBM Vendor Solutions Connectivity (VSC) Lab in Poughkeepsie, NY, USA. With this qualification testing, IBM can reproduce any concerns that might arise while using this equipment in a customer's application.

Figure 1 shows the GDPS test environment used for WDM vendor qualification.

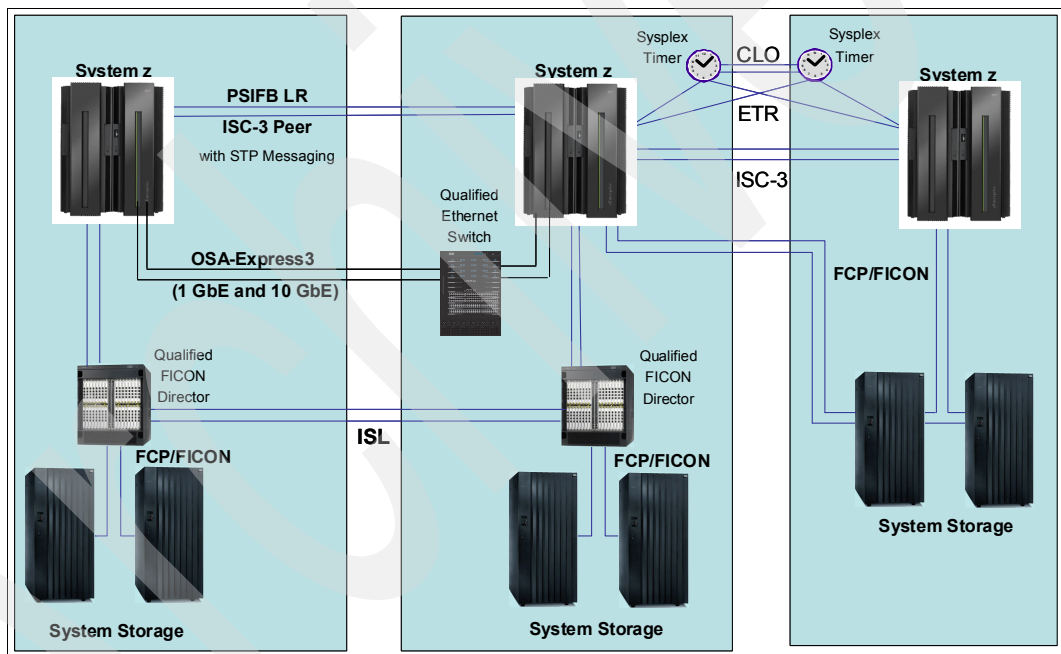

Figure 1 VSC Lab environment

Qualification testing

The VSC Lab contains System z hardware with software applications that test the interoperability of WDM products within a GDPS. A typical qualification test cycle is three to four weeks in length.

The hardware that was used for testing purposes includes (but is not limited to) the following components:

- ▶ IBM System z servers enabled for STP
- ▶ IBM 9037 Model 2 Sysplex Timers
- ▶ IBM System Storage

- ▶ IBM 9032 ESCON® Directors
- ▶ IBM System z qualified FICON® Directors
- ▶ IBM Ethernet Products

WDM links of varying distances are deployed using spools of single-mode fiber in lengths from 5 km to 50 km. Multiple spools are interconnected to test WDM link protocols up to the maximum supported distances. To achieve the maximum distances that are qualified for GDPS protocols, vendors can use optical amplifiers and dispersion compensation units, inserted at various link points, to condition the signals on the fiber links that are connected to the WDM equipment.

Operating system and application software is installed to create and to stress test the GDPS environment. The software used in the test environment includes (but is not limited to):

- ▶ z/OS, Linux® on System z and Parallel Sysplex software exploiters
- ▶ Coupling Facility Control Code (CFCC)
- ▶ IBM proprietary software and microcode utility test suites

As part of the GDPS qualification test, IBM proprietary software and microcode utility test suites drive the various GDPS components and protocols to the full data rate of each link type that is transported by the WDM equipment. This level of testing ensures that maximum channel utilization is achieved and tested to levels well beyond typical customer environments.

The test suites are used for verification of System z architecture functionality. During these functionality tests, for a test to be classified as successful, zero errors are detected by the attached subsystems. Any errors that are detected during this testing are captured and analyzed by the test suites.

The test suites are also used for verification of System z architecture recovery by creating various fault and error conditions. The recovery tests check for the correct detection of a fault or error condition by the attached subsystems, and ensure that the recovery adheres to System z architecture rules.

Some of the recovery tests performed for each link type include:

- ▶ Link state change interrupt detection and recovery: Links are deliberately broken and re-established to ensure that detection and error recovery occur correctly.
- ▶ Link error threshold and link synchronization error detection and recovery: Errors are deliberately injected, at the application and channel subsystem levels, into the link protocol data streams to ensure that detection and error recovery take place correctly.
- ▶ Link service and maintenance package recovery: Link hardware maintenance actions are performed to ensure that link state change detection and recovery take place correctly.
- ▶ Link protection schemes and recovery: Vendor-specific protection methods are tested to ensure that the expected link errors are detected and that recovery takes place correctly.
- ▶ STP timing link recovery: STP timing links are broken to ensure that changes to the Coordinated Timing Network (CTN) behave correctly when the break occurs and when the link or links are reconnected.

GDPS components and protocols

The IBM technologies that we discuss in this section are functional components of GDPS and are tested during the qualification process. Customers can also use these components in

environments that do not require a full GDPS solution. The testing provides a level of assurance that these components function when used with a qualified WDM platform.

Components

The following GDPS components are tested during the qualification process:

- ▶ IBM System z servers
- ▶ IBM Parallel Sysplex
- ▶ IBM System Storage
- ▶ IBM System Storage Metro Mirror (PPRC)
- ▶ IBM System Storage Global Mirror
- ▶ IBM System Storage z/OS Global Mirror (XRC)
- ▶ Optical Wavelength Division Multiplexer (WDM)
- ▶ IBM Ethernet Products

Protocols

Table 1 lists the GDPS connectivity protocols and their data transfer rates. Not all protocols were tested on the Cisco ONS 15454 MSTP platform. For a complete list of the protocols and interface cards that were qualified, see Table 2 on page 13.

Table 1 GDPS supported protocols

Protocol	Data transfer rate
Enterprise Systems Connection (ESCON)	200 Mbps ^a
Control Link Oscillator (CLO)	8 Mbps
External Time Reference (ETR)	8 Mbps
Fibre Connection (FICON)	1 Gbps
Fibre Connection (FICON) Express2	1, 2 Gbps
Fibre Connection (FICON) Express4	1, 2, 4 Gbps
Fibre Connection (FICON) Express8	2, 4, 8 Gbps
Fibre Channel FC100/ 200/ 400/ 800	1/ 2/ 4/ 8 Gbps
Inter-Switch Link (ISL) FC100/ 200/ 400/ 800/ 1000	1/ 2/ 4/ 8/ 10 Gbps
InterSystem Channel-3 (ISC-3) Compatibility Mode	1 Gbps
InterSystem Channel-3 (ISC-3) Peer Mode	2 Gbps
InterSystem Channel-3 (ISC-3) Peer Mode ^b	1 Gbps
STP (ISC-3 Peer Mode with STP message passing)	2 Gbps
STP (ISC-3 Peer Mode with STP message passing) ^b	1 Gbps
STP (PSIFB LR 1x IB-SDR with STP message passing)	2.5 Gbps
STP (PSIFB LR 1x IB-DDR with STP message passing)	5 Gbps
Ethernet	1, 10 Gbps

a. Effective channel data rate of an ESCON channel is affected by distance.

b. Requires RPQ 8P2197. This RPQ provides an ISC-3 Daughter Card that clocks at 1.062 Gbps in peer mode.

Often, these supported protocols are used in non-GDPS environments as well. The robust testing that is performed during the qualification process must provide customers with a high level of confidence when using these System z qualified optical WDM vendor products in non-GDPS environments.

Server Time Protocol

Server Time Protocol (STP) is designed to provide the capability for multiple servers and Coupling Facilities to maintain time synchronization with each other without requiring an IBM Sysplex Timer. STP can help provide functional and economic benefits when compared to the Sysplex Timer. STP allows concurrent migration from an External Timer Reference (ETR) network and can coexist with an ETR network.

STP is a message-based protocol in which STP timekeeping information is passed over externally defined coupling links: InterSystem Channel-3 (ISC-3) Peer Mode and Parallel Sysplex InfiniBand (PSIFB) links. ISC-3 links in Peer mode and PSIFB Long Reach (LR) are the only coupling links that can be used to transport STP messages between data centers over a WDM.

The STP design introduced a concept called Coordinated Timing Network (CTN), which is a collection of servers and Coupling Facilities that are time synchronized to a time value called Coordinated Server Time (CST). The CST represents the time for the entire network of servers. A CTN can be configured as either an STP-only CTN or a Mixed CTN. For more information, refer to *Server Time Protocol Planning Guide*, SG24-7280, *Server Time Protocol Implementation Guide*, SG24-7281, and *Server Time Protocol Recovery Guide*, SG24-7380.

Figure 2 shows a multisite STP-only CTN.

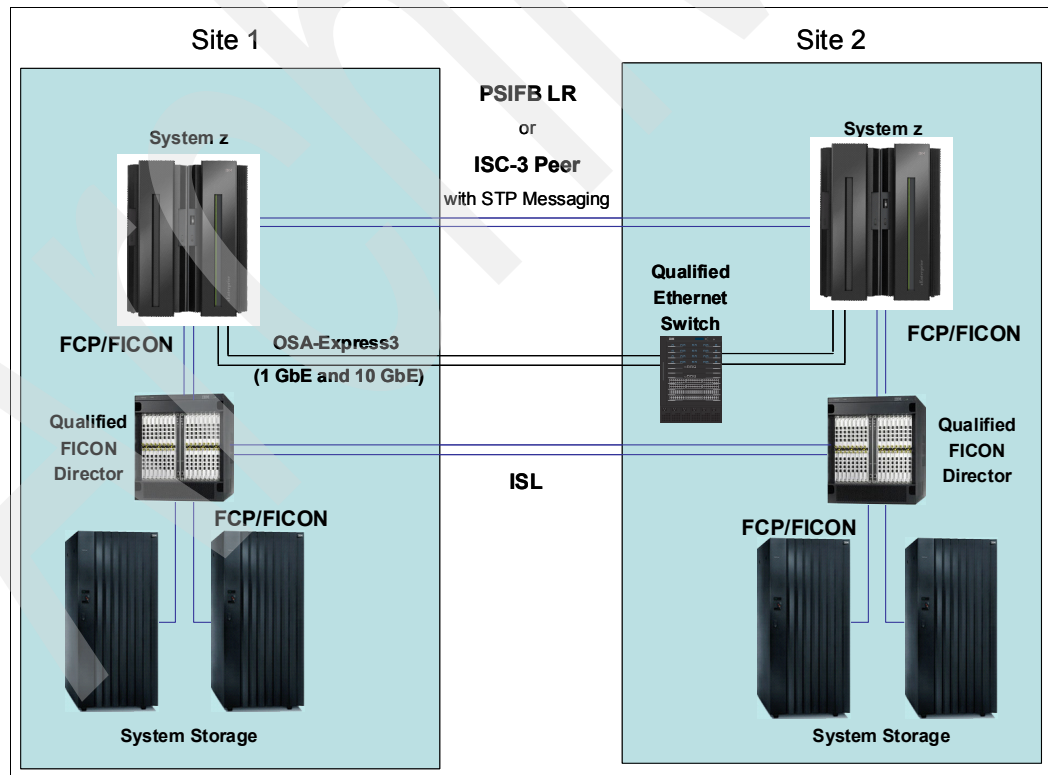

Figure 2 Multisite STP-only CTN

IBM Sysplex Timer

The IBM Sysplex Timer is a mandatory component of an ETR network and an STP Mixed CTN. The Sysplex Timer provides an External Time Reference (ETR) to synchronize the time-of-day (TOD) clocks on attached System z servers in a GDPS/PPRC environment.

Figure 3 shows a multisite ETR network.

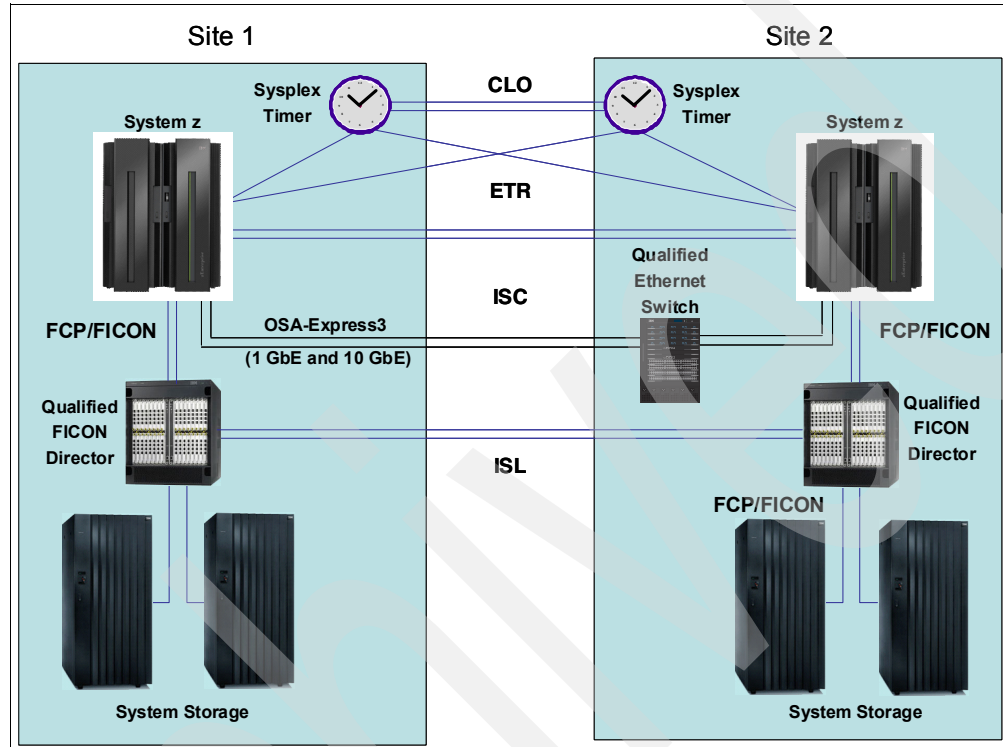

Figure 3 Multisite ETR network with Sysplex Timers

The Sysplex Timer uses two link types:

- ▶ External Time Reference (ETR)
 - ETR links are connections between the Sysplex Timer and the System z server ETR ports that provide TOD clock synchronization between multiple servers.
- ▶ Control Link Oscillator (CLO)
 - CLO links are connections between two Sysplex Timer units in an Expanded Availability configuration that allow synchronization of the Sysplex Timer timing signals.

GDPS connectivity considerations with WDM

When planning WDM intersite connectivity for GDPS environments, consider the following items:

- ▶ Differential Delay: The difference in distance or latency between a transmit fiber and a receive fiber in a single fiber pair of a timing link must adhere to the following requirements:
 - To ensure correct server time synchronization, the end-to-end lengths of the transmit and receive fibers within an individual STP link (ISC-3 Peer Mode with STP messaging or PSIFB) must not exceed the equivalent of *900 meters* differential delay between transmit and receive paths of the link. This stipulation includes all DWDM components,

optical amplifiers (OAs), dispersion compensation units (DCUs), dark fiber links, and any time division multiplexing (TDM)-based aggregation.

- To ensure correct Sysplex Timer and server time synchronization, the end-to-end lengths of the transmit and receive fibers within an individual ETR or CLO link must be equal (within *10 meters*). This stipulation includes all DWDM components, optical amplifiers (OAs), dispersion compensation units (DCUs), and dark fiber links.

Note: OAs and DCUs might contain significant lengths of fiber that must be included in the differential delay calculation for timing links.

- ▶ If both Coupling Facility data and STP timing information must be transmitted between two servers, you cannot select a subset of coupling links to be used only for STP timing information.
- ▶ Protection schemes for individual timing links or for fiber trunks transporting timing link, must be bidirectional to ensure that the correct differential delay is maintained.
- ▶ WDM configurations must have high availability topologies to ensure that there are no single points of failure.
- ▶ Fiber trunk protection schemes must be designed with two trunk switching modules and four site-to-site fiber pairs that are carried over at least two diverse routes. STP, ETR, and CLO links must connect using separate trunk switching modules to ensure that a fiber trunk protection event does not interrupt all timing links simultaneously.
- ▶ TDM-based aggregation WDM hardware can be used for STP links (ISC-3 Peer Mode or PSIFB LR with STP message passing) only if it is specifically qualified for STP usage.
- ▶ GDPS WDM configuration must be a point-to-point fixed dark fiber network.

For more information about the STP recovery process, refer to the *Server Time Protocol Recovery Guide*, SG24-7380.

Technical description

The Cisco ONS 15454 MSTP platform is a scalable, high speed fiber-optic data transport system. It consists of modular chassis, which can be interconnected to form an optical network that supports International Telecommunications Union (ITU)-specific wavelengths. The wavelengths are multiplexed onto a single pair of fibers using optical wavelength division multiplexing (WDM).

The optical network that connects the Cisco ONS 15454 MSTP can be configured in a two site point-to-point, multisite ring or meshed network (for GDPS IBM qualifies point-to-point topologies only).

A fully configured point-to-point network can consist of up to 80 protected ITU wavelengths over multiple fiber pairs (trunks) that are connected between data sites. Multiple client interfaces can be aggregated onto a single wavelength with the use of Muxponder interface cards.

The Cisco ONS 15454 MSTP platform was qualified using software release level 9.2. It has a modular chassis that is capable of housing multiple optical interface cards depending on the chassis. Multiple Cisco ONS 15454 MSTP chassis can be interconnected to support larger quantities of client interfaces.

Interface cards and modules

This section includes a detailed list of the Cisco ONS 15454 MSTP optical interface cards and modules that are qualified by System z GDPS Testing.

Optical interface cards and modules:

► **Transponder cards**

Transponder cards connect client equipment to the WDM platform. The Transponder card converts client optical signals to an ITU-compliant DWDM wavelength for transmission to the remote site.

Cisco ONS 15454 MSTP Transponder cards have pluggable client optical transceivers.

The qualified Cisco ONS 15454 MSTP Transponder card types are:

- 15454-MR-L1-xx.x, Multirate 2.5-Gbps Transponder card 4 Channel ITU Tunable
- 15454-10EX-L1-C, Extended Performance 10-Gbps Multirate Transponder Card, Full Band-C ITU Tunable
- 15454-OTU2-XP, 4 Port XFP 10-Gbps Transponder card, with pluggable network transceivers, Full Band-C ITU Tunable or one fixed Channel ITU

► **Muxponder cards**

The Cisco ONS 15454 MSTP supports the aggregation of client signals. Muxponder cards use time division multiplexing (TDM) to aggregate multiple client optical interfaces for transport over a single ITU specific wavelength.

Muxponder cards have pluggable client optical transceivers that support different client protocols and fiber types.

The qualified Cisco ONS 15454 MSTP Muxponder card types are:

- 15454-10DME-C, 8-port 10-Gbps Data Muxponder Full Band-C ITU Tunable
- 15454-DM-L1-xx.x, 8-port 2.5-Gbps Data Muxponder 4 Channel ITU Tunable
- 15454-10DMEX-C, 8-port Extended Performance 10-Gbps Data Muxponder Full Band-C ITU Tunable
- 15454-40G-MXP-C, 4-port 40-Gbps Data Muxponder Full Band-C ITU Tunable

► **Optical Filter Modules**

The Optical Filter Modules are optical components that combine (multiplex) or separate (demultiplex) multiple optical signals onto a fiber link.

Using reconfigurable optical add-drop multiplexer (ROADM) you can add or drop optical signals at the wavelengths layer without an optical-electrical-optical conversion in multiple directions in an optical cross-connect system.

The main component of the ROADM is the Wavelength Selective Switch (WSS) which combines the multiplexing/demultiplexing functionality with per-wavelength optical signal switching.

► **Optical Amplifier (OA)**

Optical amplifier module provides in-line optical amplification of multiple ITU-specific wavelengths within a fiber. For some extended distances, the use of these erbium doped fiber amplifiers (EDFAs) might be required. EDFAs cannot be used to amplify CWDM signals.

- ▶ Dispersion Compensation Unit (DCU)

Dispersion Compensation Unit provide compensation to chromatic dispersion fiber impairment, which causes signal degradation and limits the transmission distance.

Fiber: OAs and DCUs contain significant lengths of fiber, which must be included in the differential delay calculation for timing links.

- ▶ Protection Switch Module (PSM)

The Cisco ONS 15454 MSTP supports optically switched fiber protection for point-to-point DWDM links with the use of the Protection Switch Module (PSM). The PSM protects site-to-site traffic from physical damage to a fiber or fiber pair by switching bidirectionally to a redundant fiber or fiber pair.

The qualified Cisco ONS 15454 MSTP Protection Switch Module types are:

- 15454-PSM, Optical Protection Switching Module

Topologies and protection schemes

System z qualifies a two-site point-to-point WDM network topology and protection against failures in site-to-site fiber links or failures in individual components within the WDM network for GDPS.

GDPS is a high-availability solution that can utilize several protection schemes. Some restrictions apply for particular protocols, for example, Sysplex Timer (ETR/CLO) and STP (ISC-3 Peer Mode and PSIFB LR) links.

Important: Protection schemes must guarantee the correct differential delay for individual timing links:

- ▶ STP links must not exceed the equivalent of *900 meters* differential delay between transmit and receive paths of the link.
- ▶ ETR and CLO links must not exceed the equivalent of *10 meters* differential delay between transmit and receive paths of the link.

Protection schemes

The Cisco ONS 15454 MSTP platform provides the following protection schemes:

- ▶ Unprotected

An unprotected Transponder/Muxponder card is connected to one client interface and to one site-to-site fiber link only. A failure of the Transponder/Muxponder card or the site-to-site fiber link results in a loss of client communications.

- ▶ Client-based protection

Client-based protection uses at least two client interfaces that are connected to the WDM. These interfaces are arranged so that the Transponder/Muxponder cards that connect the two sites are distributed over two diverse site-to-site fiber links. The client device is responsible for ensuring that a failure of a WDM module or of a single site-to-site fiber link does not result in a total loss of client communications.

GDPS timing links (ETR, CLO, and STP) are qualified for use in a client-based protection scheme if they are using separate paths (routes).

Note: For simplicity, we do not show all components in the optical path in the diagrams in this section.

Figure 4 shows a high-level view of the client-based protection scheme. In this case, a client device has two separate site-to-site connections: one through Card A and the other through Card B. Transponder Card and Muxponder Card-based schemes for the Cisco ONS 15454 MSTP are shown separately.

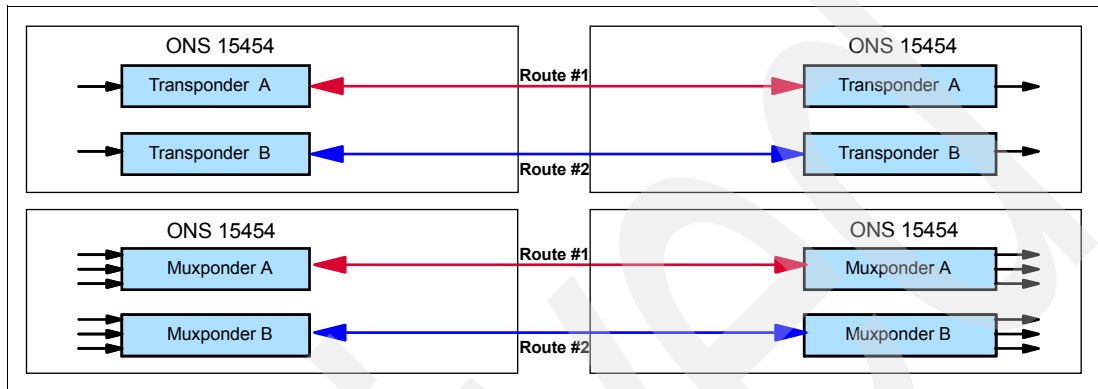

Figure 4 Client-based protected scheme

► **Optically Switched Fiber protection**

The Protection Switch Module (PSM) provides protection at the site-to-site fiber level. The PSM protects all wavelengths that are being carried on a fiber pair simultaneously. In the event of a site-to-site fiber failure, all traffic is switched bi-directionally to the backup link.

The PSM is only available for point-to-point WDM network topologies.

Figure 5 shows a high-level view of the Optically Switched Fiber protection scheme.

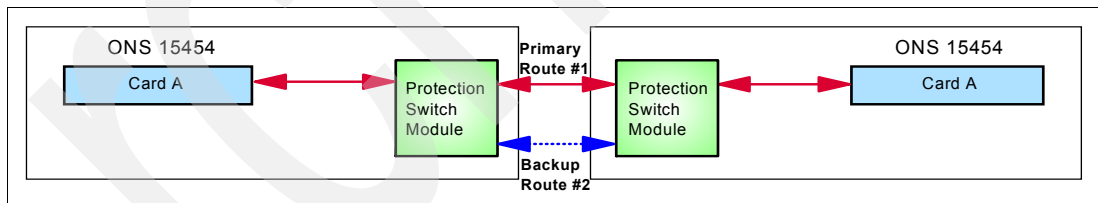

Figure 5 Optically Switched Fiber protection

GDPS timing links (STP, ETR, and CLO) are not qualified for use with a single PSM at each site. A single PSM-based, Optically Switched Fiber protection scheme must not be used with GDPS/PPRC. It must be used in conjunction with Client-based protection scheme.

If a GDPS/PPRC solution is to use Optically Switched Fiber protection, then dual PSMs at each site, with four site-to-site fiber pairs (trunks) are recommended. The GDPS timing links must connect using different cards and PSMs.

Figure 6 on page 12 shows a high-level view of the dual Optically Switched Fiber protection scheme.

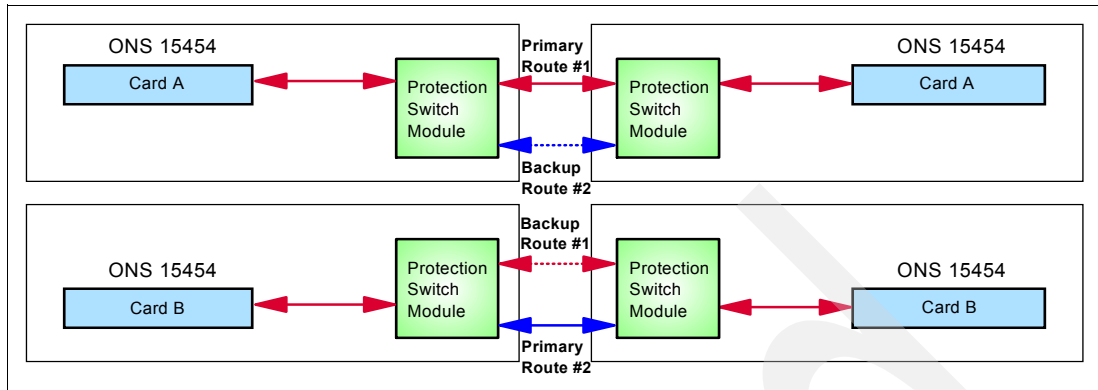

Figure 6 Dual Optically Switched Fiber protection

► Y-Cable Line Card Protection

Y-Cable Line Card protection provides per wavelength protection against a Transponder module failure, and also against a site-to-site fiber failure. The signal received from the client is optically split using a Y-Cable and connected into two Transponder modules. The Transponder modules are configured to send their trunk facing signals over two diverse site-to-site fiber links. At the remote site, WDM control logic ensures that the client facing transmit laser of only one Transponder module is enabled for the remote client interface.

Transponder based Y-Cable Line Card protection is supported on the Cisco ONS 15454 MSTP.

GDPS timing links (STP, ETR, and CLO) are not qualified for use with Y-Cable.

Figure 7 shows a high-level view of the Y-Cable Line Card protection scheme.

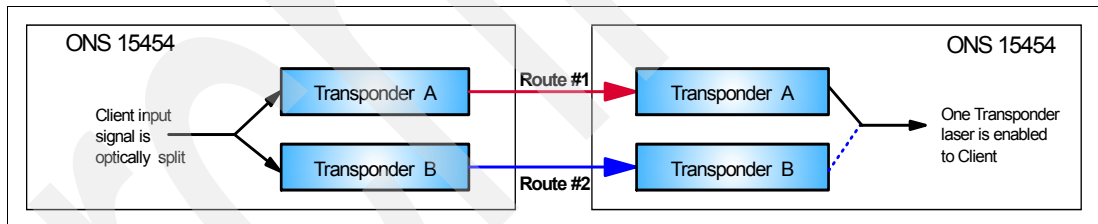

Figure 7 Y-Cable Line card protected scheme

Protection scheme intermix

All schemes can be intermixed within the same Cisco ONS 15454 MSTP chassis or network on a per client interface basis.

Interface card specifications

Table 2 on page 13 lists the specifications of the qualified Cisco ONS 15454 MSTP interface cards and tested protocols.

Cisco ONS 15454 MSTP interface cards do not support auto-negotiation of link speeds. For System z FICON and FCP client links, the desired link speed must be configured in the WDM card client interface at both ends of the link.

For some extended distances, the use of optical amplifiers and dispersion compensation units might be required. Refer to the WDM vendor documentation for distance and link budget specifications.

Table 2 Qualified client interface card details

Card Type / Protocol	Fiber type	Light source	Qualified distance ^{a,b}
15454-MR-L1-xx.x, Multirate 2.5-Gbps transponder card 4 Channel ITU Tunable^c			
CLO (8 Mbps)	MM	1310 nm	40 km
ETR (8 Mbps)	MM	1310 nm	100 km
ISC-3 Peer Mode (1, 2 Gbps) ^d	SM	1310 nm	200 km
STP (ISC-3 Peer Mode with STP messaging) ^d	SM	1310 nm	100 km, 200 km
15454-10EX-L1-C, Extended performance 10-Gbps multirate transponder full band-C ITU tunable^c			
ISL (10 Gbps) ^e	SM	1310 nm	175 km
ISL (10 Gbps) ^e	MM	850 nm	175 km
STP (PSIFB 1x IB-DDR LR) (5 Gbps)	SM	1310 nm	100 km
15454-10DME-C, 8-port 10-Gbps data muxponder full band-C ITU tunable^c			
FICON (1, 2, 4 Gbps)	SM	1310 nm	300 km
FICON (1, 2, 4 Gbps)	MM	850 nm	300 km
Fibre Channel (1, 2, 4 Gbps)	SM	1310 nm	300 km
Fibre Channel (1, 2, 4 Gbps)	MM	850 nm	300 km
ISC-3 Compatibility Mode (1 Gbps)	SM	1310 nm	40 km
ISC-3 Peer Mode (1, 2 Gbps) ^d	SM	1310 nm	100 km, 200 km
15454-DM-L1-xx.x, 8-port 2.5-Gbps data muxponder 4 channel ITU tunable^c			
ESCON/SBCON (200 Mbps)	MM	1310 nm	100 km
ISL (2 Gbps) ^e	SM	1310 nm	300 km
ISL (2 Gbps) ^e	MM	850 nm	300 km
15454-10DMEX-C, extended performance 8-port 10-Gbps data muxponder full band-C ITU tunable^c			
FICON (1, 2, 4 Gbps)	SM	1310 nm	300 km
FICON (1, 2, 4 Gbps)	MM	850 nm	300 km
Fibre Channel (1, 2, 4 Gbps)	SM	1310 nm	300 km
Fibre Channel (1, 2, 4 Gbps)	MM	850 nm	300 km
ISC-3 Compatibility Mode (1 Gbps)	SM	1310 nm	40 km
ISC-3 Peer Mode (1, 2 Gbps) ^d	SM	1310 nm	100 km, 200 km
15454-OTU2-XP, 4-port 10-Gbps XFP transponder full band-C ITU tunable^c			
ISL (10 Gbps) ^e	SM	1310 nm	175 km
ISL (10 Gbps) ^e	MM	850 nm	175 km
STP (PSIFB 1x IB-DDR LR) (5 Gbps)	SM	1310 nm	100 km
15454-40G-MXP-C, 4-port 40-Gbps data muxponder full band-C ITU tunable^c			
FICON (8 Gbps)	SM	1310 nm	300 km
Fibre Channel (8 Gbps)	SM	1310 nm	300 km
ISL (8 Gbps) ^e	SM	1310 nm	300 km
ISL (10 Gbps) ^e	SM	1310 nm	300 km

Card Type / Protocol	Fiber type	Light source	Qualified distance ^{a, b}
ISL (10 Gbps) ^e	MM	850 nm	300 km
SM = single-mode fiber (9/125 micron) MM = multimode fiber (50/125 or 62.5/125 micron)			

- a. Qualified distance is based on the VSC Lab test environment, which is a physical point-to-point topology without any intermediate nodes besides OAs and DCUs.
- b. Requires RPQ 8P2263 or 8P2340 for distances over 100 km.
- c. Protocol and wavelength support is dependent on pluggable client interface transceiver.
- d. To support ISC-3 Peer at 1 Gbps (RPQ 8P2197), configure the WDM interface protocol as Fibre Channel FC100 (1 Gbps).
- e. Protocol is configured as Fibre Channel protocol on WDM.

Note: Consult your SAN switch vendors for qualified ISL supported distances.

References

For more information about System z connectivity, see:

- ▶ System z I/O connectivity home page
<http://www.ibm.com/systems/z/hardware/connectivity/index.html>
- ▶ *IBM System z Connectivity Handbook*, SG24-5444
<http://www.redbooks.ibm.com/abstracts/sg245444.html?Open>
- ▶ *FICON Planning and Implementation Guide*, SG24-6497
<http://www.redbooks.ibm.com/abstracts/sg246497.html?Open>
- ▶ *Getting Started with InfiniBand on System z10 and System z9*, SG24-7539
<http://www.redbooks.ibm.com/abstracts/sg247539.html?Open>

For more information about GDPS, see:

- ▶ GDPS home page
<http://www.ibm.com/systems/z/advantages/gdps/index.html>
- ▶ *GDPS Family An Introduction to Concepts and Capabilities*, SG24-6374
<http://www.redbooks.ibm.com/abstracts/sg246374.html?Open>

For more information about STP, see:

- ▶ Parallel Sysplex home page
<http://www.ibm.com/systems/z/advantages/psp/index.html>
- ▶ *Server Time Protocol Planning Guide*, SG24-7280
<http://www.redbooks.ibm.com/abstracts/sg247280.html?Open>
- ▶ *Server Time Protocol Implementation Guide*, SG24-7281
<http://www.redbooks.ibm.com/abstracts/sg247281.html?Open>
- ▶ *Server Time Protocol Recovery Guide*, SG24-7380
<http://www.redbooks.ibm.com/abstracts/sg247380.html?Open>

For more information about optical communication:

- *Understanding Optical Communications*, SG24-5230

<http://www.redbooks.ibm.com/abstracts/sg245230.html?Open>

For current information about qualified WDM vendor products, registered users can visit the Library at the Resourcelink web site:

<https://www.ibm.com/servers/resourcelink/lib03020.nsf/pages/systemzQualifiedWdmProductsForGdpsSolutions?OpenDocument&pathID=>

For current information about qualified vendor switches and directors for IBM System z FICON and FCP channels, registered users can visit the Library at the Resourcelink web site:

<https://www.ibm.com/servers/resourcelink/lib03020.nsf/pages/switchesAndDirectorsQualifiedForIbmSystemZRFiconRAndFcpChannels?OpenDocument>

IBM Redbooks publications on System z qualified WDM vendor products can be found at:

<http://www.redbooks.ibm.com/cgi-bin/searchsite.cgi?query=qualified+AND+wdm&SearchOrder=1&SearchFuzzy=>

For more information about the Cisco ONS 15454 MSTP platform, see:

<http://www.cisco.com/en/US/products/hw/optical/ps2006/ps5320/index.html>

The team who wrote this Redpaper

This Redpaper was produced by a team of specialists working at the International Technical Support Organization, Poughkeepsie Center.

Bill White is a Project Leader and Senior Networking and Connectivity Specialist at the International Technical Support Organization, Poughkeepsie Center.

Pasquale Catalano is a Staff Engineer at the IBM Vendor Solutions Connectivity Lab in Poughkeepsie, NY, USA. He has eight years of experience in WDM vendor qualification testing. He has a Masters of Science in Electrical Engineering from the State University of New York at New Paltz.

Michal Holenia is a Senior Network IT Architect and Integrated Communication Services Leader in IBM Slovakia. He has 12 years of field experience with IBM, including Data Center Networking and WDM products. He is a Cisco Certified Internetwork Expert, ADVA Certified Expert, and Certified Information Systems Security Professional. He provides consulting, design, implementation, and technical support for LAN, WAN, SAN, MAN, and Private Optical Network WDM solutions.

Pasi Laakso is an IBM Certified IT Specialist at ICS in IBM Finland. He has 10 years of field experience with IBM, including Networking and WDM products. He is a Cisco Certified Internetwork Expert and ADVA Certified Expert. He provides consulting, design, implementation, and technical support for Data Center Networking, Optimization Services and Private Optical Network WDM solutions.

Thanks to the following people for their contributions to this project:

Connie Beuselinck
System z Hardware Product Planning, IBM Poughkeepsie

Casimer DeCusatis
Distinguished Engineer, STG Development, IBM Poughkeepsie

Noshir Dhondy
System z Hardware Brand Technology, IBM Poughkeepsie

Charles Grizzaffi
System z WDM Program Manager, IBM Poughkeepsie

Rav Meerwald
Advanced Account System Service Representative, IBM Australia

Jeff Nesbitt
Advanced Account System Service Representative, IBM Australia

David Raften
System z Parallel Sysplex and GDPS Planning, IBM Poughkeepsie

Now you can become a published author, too!

Here's an opportunity to spotlight your skills, grow your career, and become a published author - all at the same time! Join an ITSO residency project and help write a book in your area of expertise, while honing your experience using leading-edge technologies. Your efforts will help to increase product acceptance and customer satisfaction, as you expand your network of technical contacts and relationships. Residencies run from two to six weeks in length, and you can participate either in person or as a remote resident working from your home base.

Find out more about the residency program, browse the residency index, and apply online at: ibm.com/redbooks/residencies.html

Stay connected to IBM Redbooks

- ▶ Find us on Facebook:
<http://www.facebook.com/IBMRedbooks>
- ▶ Follow us on Twitter:
<http://twitter.com/ibmredbooks>
- ▶ Look for us on LinkedIn:
<http://www.linkedin.com/groups?home=&gid=2130806>
- ▶ Explore new Redbooks publications, residencies, and workshops with the IBM Redbooks weekly newsletter:
<https://www.redbooks.ibm.com/Redbooks.nsf/subscribe?OpenForm>
- ▶ Stay current on recent Redbooks publications with RSS Feeds:
<http://www.redbooks.ibm.com/rss.html>

Archived

Notices

This information was developed for products and services offered in the U.S.A.

IBM may not offer the products, services, or features discussed in this document in other countries. Consult your local IBM representative for information on the products and services currently available in your area. Any reference to an IBM product, program, or service is not intended to state or imply that only that IBM product, program, or service may be used. Any functionally equivalent product, program, or service that does not infringe any IBM intellectual property right may be used instead. However, it is the user's responsibility to evaluate and verify the operation of any non-IBM product, program, or service.

IBM may have patents or pending patent applications covering subject matter described in this document. The furnishing of this document does not give you any license to these patents. You can send license inquiries, in writing, to:

IBM Director of Licensing, IBM Corporation, North Castle Drive, Armonk, NY 10504-1785 U.S.A.

The following paragraph does not apply to the United Kingdom or any other country where such provisions are inconsistent with local law: INTERNATIONAL BUSINESS MACHINES CORPORATION PROVIDES THIS PUBLICATION "AS IS" WITHOUT WARRANTY OF ANY KIND, EITHER EXPRESS OR IMPLIED, INCLUDING, BUT NOT LIMITED TO, THE IMPLIED WARRANTIES OF NON-INFRINGEMENT, MERCHANTABILITY OR FITNESS FOR A PARTICULAR PURPOSE. Some states do not allow disclaimer of express or implied warranties in certain transactions, therefore, this statement may not apply to you.

This information could include technical inaccuracies or typographical errors. Changes are periodically made to the information herein; these changes will be incorporated in new editions of the publication. IBM may make improvements and/or changes in the product(s) and/or the program(s) described in this publication at any time without notice.

Any references in this information to non-IBM Web sites are provided for convenience only and do not in any manner serve as an endorsement of those Web sites. The materials at those Web sites are not part of the materials for this IBM product and use of those Web sites is at your own risk.

IBM may use or distribute any of the information you supply in any way it believes appropriate without incurring any obligation to you.

Information concerning non-IBM products was obtained from the suppliers of those products, their published announcements or other publicly available sources. IBM has not tested those products and cannot confirm the accuracy of performance, compatibility or any other claims related to non-IBM products. Questions on the capabilities of non-IBM products should be addressed to the suppliers of those products.

This information contains examples of data and reports used in daily business operations. To illustrate them as completely as possible, the examples include the names of individuals, companies, brands, and products. All of these names are fictitious and any similarity to the names and addresses used by an actual business enterprise is entirely coincidental.

COPYRIGHT LICENSE:

This information contains sample application programs in source language, which illustrate programming techniques on various operating platforms. You may copy, modify, and distribute these sample programs in any form without payment to IBM, for the purposes of developing, using, marketing or distributing application programs conforming to the application programming interface for the operating platform for which the sample programs are written. These examples have not been thoroughly tested under all conditions. IBM, therefore, cannot guarantee or imply reliability, serviceability, or function of these programs.

This document REDP-4719-00 was created or updated on February 4, 2011.



Send us your comments in one of the following ways:

- ▶ Use the online **Contact us** review Redbooks form found at:
ibm.com/redbooks
- ▶ Send your comments in an email to:
redbooks@us.ibm.com
- ▶ Mail your comments to:
IBM Corporation, International Technical Support Organization
Dept. HYTD Mail Station P099
2455 South Road
Poughkeepsie, NY 12601-5400 U.S.A.



Trademarks

IBM, the IBM logo, and ibm.com are trademarks or registered trademarks of International Business Machines Corporation in the United States, other countries, or both. These and other IBM trademarked terms are marked on their first occurrence in this information with the appropriate symbol (® or ™), indicating US registered or common law trademarks owned by IBM at the time this information was published. Such trademarks may also be registered or common law trademarks in other countries. A current list of IBM trademarks is available on the Web at <http://www.ibm.com/legal/copytrade.shtml>

The following terms are trademarks of the International Business Machines Corporation in the United States, other countries, or both:

ESCON®	Redbooks®	System z9®
FICON®	Redpaper™	System z®
GDPS®	Redbooks (logo) ®	z/OS®
Geographically Dispersed Parallel Sysplex™	Resource Link™	z10™
IBM®	Sysplex Timer®	z9®
Parallel Sysplex®	System Storage®	
	System z10®	

The following terms are trademarks of other companies:

Linux is a trademark of Linus Torvalds in the United States, other countries, or both.

Other company, product, or service names may be trademarks or service marks of others.